

GEARED MOTOR

G TYPE GEARBOX

- MOTOR MODEL:
7SRDG□-10G (NO FAN)

- GEARBOX MODEL:
7GBK□BMH

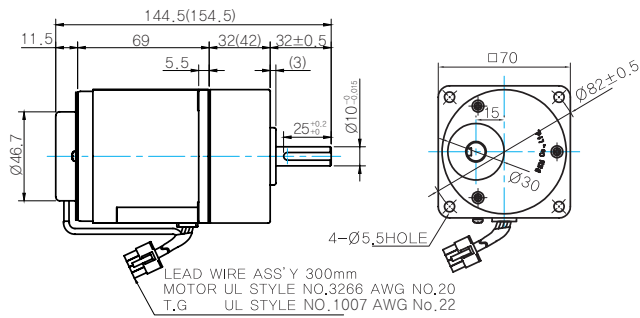

GEARBOX OUTPUT SHAFT

MODEL	SPEC
KEY TYPE	

KEY SPEC

GEARBOX	

WEIGHT

PART	WEIGHT(Kg)
MOTOR	0,93
7GBK3BMH - 7GBK18BMH	0,38
7GBK20BMH - 7GBK40BMH	0,48
7GBK50BMH - 7GBK200BMH	0,53

32(42)-Table1

SIZE(mm)	GEAR RATIO
32	7GBK3BMH - 7GBK18BMH
42	7GBK20BMH - 7GBK200BMH

Motor Images

